



METEOROLOGICAL INSTRUMENTS

INSTRUCTIONS

**WIND MONITOR
INTRINSICALLY SAFE WITH 4-20mA OUTPUTS
MODEL 05501LM**



MODEL 05501LM
WIND MONITOR
 Intrinsically Safe with 4-20 mA Outputs



INTRODUCTION

Model 05501LM Wind Monitor IS is an intrinsically safe wind sensor that converts horizontal wind speed and direction measurements to calibrated 4-20 mA signals. Each signal is derived from independent 2-wire loop-powered circuits. The sensor operates over a wide ambient temperature range.

Intrinsic safety is achieved when the sensor is used with approved barriers. Intrinsically safe systems are recognized as practical and effective means of operating instruments in an explosive environment. The technique limits the amount of energy available to ignite explosive gases or ignitable mixtures. This is accomplished by controlling the amount of voltage and current in the hazardous area.

When used with an approved Intrinsically Safe barrier, the Wind Monitor IS can be used in Class 1, Division 1, Group A,B,C,D hazardous areas. The categories are defined as follows:

- Class I Locations in which flammable gases or vapors are or may be present in quantities sufficient to produce explosive or ignitable mixtures.
- Division 1 Locations in which hazardous concentrations in the air exist continuously, intermittently, or periodically under normal operating conditions.
- Group A Atmospheres containing acetylene
- Group B Atmospheres containing hydrogen, or gases or vapors of equivalent hazard, such as manufactured gas.
- Group C Atmospheres containing ethyl-ether vapors, ethylene, or cyclo-propane
- Group D Atmospheres containing gasoline, hexane, naptha, benzine, butane, propane, alcohol, acetone, benzol, lacquer solvent vapors, or natural gas.

WIND SPEED SPECIFICATION SUMMARY

Operating Range	0 to 60 m/s (134 mph)
Gust Survival	100 m/s (220 mph)
Sensor Type	18 cm diameter 4-blade helicoid polypropylene propeller, 29.4 cm air passage per revolution
Distance Constant	2.7 m (8.9 ft.) for 63% recovery
Threshold Sensitivity	1.0 m/s (2.2 mph)
Output Signal	4-20 mA for 0 to 50 m/s (100 m/s optional)
Power Requirement:	10 to 30 VDC at 20 mA max

WIND DIRECTION (AZIMUTH) SPECIFICATION SUMMARY

Range	360° mechanical, 355° electrical (5° open)
Sensor	Balanced vane, 38 cm (15 in) turning radius.
Damping Ratio	0.3
Delay Distance	1.3 m (4.3 ft) for 50% recovery
Threshold Sensitivity	1.1 m/s (2.4 mph) at 10° displacement
Natural Wavelength	7.4 m (24.3 ft) Damped 7.2 m (23.6 ft) Undamped
Output Signal	4-20 mA for 0 to 360°
Power Requirement:	10 to 30 VDC at 20 mA max

GENERAL

Ambient Temperature	-50 to 50°C (-58 to 122°F)
Intrinsic Safety	Class I, Division 1, Groups A, B, C, D when installed with approved Intrinsically Safe Barrier (see Wiring Diagram)
Entity Approval	Vmax = 30V Imax = 100 mA Ci = 0.01 uF Li = 0.0 uH

The Wind Monitor IS is rugged and corrosion resistant, yet accurate and lightweight. Housing, nose cone, propeller, and other components are injection molded with U.V. stabilized plastic. Both the propeller and vertical shafts use stainless steel precision grade ball bearings.

Propeller rotation produces an AC sine wave signal with frequency proportional to wind speed. Internal circuitry converts this signal to a calibrated 4 to 20 mA current output.

Vane position is sensed by a 10K ohm precision conductive plastic potentiometer. This signal is also converted to 4 to 20mA output.

The instrument mounts directly on a standard one inch pipe, outside diameter 34 mm (1.34"). An orientation ring is provided so the instrument can be removed for maintenance and re-installed without loss of wind direction reference. Both sensor and orientation ring are secured to the mounting pipe by stainless steel band clamps. Electrical connections are made in a junction box at the base.

INITIAL CHECK-OUT

When the instrument is unpacked, check it carefully for signs of shipping damage.

Remove the plastic nut on the propeller shaft. Install the propeller on the shaft with the serial number of the propeller facing forward (into the wind). The instrument is aligned, balanced and fully calibrated before shipment; however, it should be checked both mechanically and electrically before installation. The vane and propeller should

easily rotate 360° without friction. Check vane balance by holding the instrument base so the vane surface is horizontal. It should have near neutral torque without any particular tendency to rotate. A slight imbalance will not degrade performance.

INSTALLATION

PROPER ELECTRICAL CONNECTION IS CRITICAL FOR SAFE USE IN HAZARDOUS LOCATIONS. FAILURE TO DO SO COULD RESULT IN INJURY TO PERSONS OR PROPERTY DAMAGE.

AN APPROVED INTRINSICALLY SAFE BARRIER MUST BE USED.

REFER TO WIRING DIAGRAM FOR CONNECTION DETAILS. FOLLOW BARRIER MANUFACTURER'S GUIDELINES FOR CORRECT INSTALLATION.

OBSERVE NEC CODES FOR WIRING IN HAZARDOUS LOCATIONS OR EQUIVALENT.

The Wind Monitor IS must be connected through an approved Intrinsically Safe barrier or its equivalent. Examples of approved barriers include the following models from MTL (www.mtl-inst.com):

MTL 7087+	Passive diode barrier with resistors
MTL 7106	Diode barrier with active electronics
MTL 7206	Diode barrier with active electronics
MTL 5041	Isolated barrier with active electronics
MTL 5044	2-ch version of MTL5041

Entity Parameters for the Wind Monitor IS are as follows:

V _{max}	=	30 VDC
I _{max}	=	100 mA
L _i	=	0.0 uH
C _i	=	0.01 uF

Any approved barrier may be used provided that its specifications and the wiring connections fulfill the following relationship:

V _{max}	>	V _{oc}
I _{max}	>	I _{sc}
L _a	>	L _i + L _w
C _a	>	C _i + C _w

Where:

V _{max}	=	30 VDC Max Open Circuit Voltage of 05501LM
I _{max}	=	100 mA Max Short Circuit Current of 05501LM
L _i	=	0.0 uH Inductance of 05501LM
C _i	=	0.01 uF Capacitance of 05501LM

L _w	=	Connecting Wire Inductance
C _w	=	Connecting Wire Capacitance

V _{oc}	=	Maximum Open Circuit Voltage of IS Barrier
I _{sc}	=	Maximum Short Circuit Current of IS Barrier
L _a	=	Maximum Allowed Inductance of IS Barrier
C _a	=	Maximum Allowed Capacitance of IS Barrier

Accurate wind measurements require proper instrument placement. Eddies from trees, buildings, or other structures can greatly influence wind speed and direction observations. To get meaningful data for most applications, locate the instrument well above or upwind from obstructions. As a general rule, the air flow around a structure is

disturbed to twice the height of the structure upwind, six times the height downwind, and up to twice the height of the structure above ground. For some applications it may not be practical or necessary to meet these requirements.

Initial installation is most easily done with two people; one to adjust the instrument position and the other to observe the indicating device. After initial installation, the instrument can be removed and returned to its mounting without realigning the vane since the orientation ring preserves the wind direction reference. Install the Wind Monitor following these steps:

1. MOUNT WIND MONITOR
 - a) Place orientation ring on mounting post. Do Not tighten band clamp yet. Orientation ring may be omitted when portable tripod is used.
 - b) Place Wind Monitor on mounting post. Do Not tighten band clamp yet.
2. CONNECT SENSOR CABLE.
 - a) Refer to diagram W05501L located at back of manual.
3. ALIGN VANE
 - a) Connect instrument to indicator.
 - b) Choose a known wind direction reference point on the horizon.
 - c) Sighting down instrument centerline, point nose cone at reference point on horizon.
 - d) While holding vane in position, slowly turn base until indicator shows proper value.
 - e) Tighten mounting post band clamp.
 - f) Engage orientation ring indexing pin in notch at instrument base.
 - g) Tighten orientation ring band clamp.

CALIBRATION CHECK

The Wind Monitor IS is fully calibrated before shipment and should require no adjustments. Periodic calibration checks are desirable and may be necessary if the instrument is used in programs which require auditing of sensor performance.

WIND DIRECTION

Place the instrument on a Young Model 18112 Vane Angle Bench Stand. Connect the instrument to a signal conditioning circuit which indicates wind direction. Move the vane to various angular orientations on the Vane Angle Bench Stand and observe the Wind Monitor output. Indicated vane angle should agree with actual angle within ±3°. If measuring current output, use the following formula:

$$mA = 4 + 16 \times \left(\frac{\text{angle}}{360} \right)$$

Note that while the sensor mechanically rotates through a full 360°, the active region of the sensor ends at 355°. This means that the highest obtainable reading occurs at 19.8 mA.

$$19.8 \approx 16 \times \left(\frac{355}{360} \right) + 4$$

WIND SPEED

Remove the propeller and connect a Young Model 18802 Anemometer Drive to the propeller shaft. Connect the instrument to a signal conditioning circuit indicating wind speed.

Set the Anemometer Drive to various rates and observe the Wind Monitor output. Indicated speed should agree with actual speed within ± 0.5 m/s. Use the following formulas:

$$mA = 4 + 16 \times \left(\frac{\text{speed}}{50} \right)$$
$$\text{speed} = 0.0049 \times \text{RPM}$$

Speed is in meters per second (m/s).

Details on checking bearing torque, which affects wind speed and direction threshold, appear in the following section.

MAINTENANCE

Given proper care, the Wind Monitor should provide years of service. The only components likely to need replacement due to normal wear are the precision ball bearings and the wind direction potentiometer. Only a qualified instrument technician should perform the replacement. If service facilities are not available, return the instrument to the company. Refer to the drawings to become familiar with part names and locations. The asterisk * which appears in the following outlines is a reminder that maximum torque on all set screws is 80 oz-in.

ELECTRONIC REPAIR MAY BE PERFORMED ONLY BY QUALIFIED TECHNICIANS.

SUBSTITUTION OF COMPONENTS MAY IMPAIR INTRINSIC SAFETY.

POTENTIOMETER REPLACEMENT

The potentiometer has a life expectancy of fifty million revolutions. As it becomes worn, the element may begin to produce noisy signals or become nonlinear. When signal noise or non-linearity becomes unacceptable, replace the potentiometer. Refer to exploded view drawing and proceed as follows:

1. REMOVE MAIN HOUSING
 - a) Unscrew nose cone from main housing. Set o-ring aside for later use.
 - b) Gently push main housing latch.
 - c) While pushing latch, lift main housing up and remove it from vertical shaft bearing rotor.
2. UNSOLDER TRANSDUCER WIRE
 - a) Remove junction box cover, exposing circuit board.
 - b) Remove screws holding circuit board.
 - c) Unsolder three potentiometer wires (white, green, black), two wind speed coil wires (red, black) and earth ground wire (red) from board.
3. REMOVE POTENTIOMETER
 - a) Loosen set screw on potentiometer coupling and remove it from potentiometer adjust thumbwheel.
 - b) Loosen set screw on potentiometer adjust thumbwheel and remove it from potentiometer shaft.
 - c) Loosen two set screws at base of transducer assembly and remove assembly from vertical shaft.
 - d) Unscrew potentiometer housing from potentiometer mounting & coil assembly.

- e) Push potentiometer out of potentiometer mounting & coil assembly by applying firm but gentle pressure on potentiometer shaft. Make sure that the shaft o-ring comes out with the potentiometer. If not, then gently push it out from the top of the coil assembly.

4. INSTALL NEW POTENTIOMETER

- a) Push new potentiometer into potentiometer mounting & coil assembly making sure o-ring is on shaft.
- b) Feed potentiometer and coil wires through hole in bottom of potentiometer housing.
- c) Screw potentiometer housing onto potentiometer mounting & coil assembly.
- d) Gently pull transducer wires through bottom of potentiometer housing to take up any slack. Apply a small amount of silicone sealant around hole.
- e) Install transducer assembly on vertical shaft allowing 0.5 mm (0.020") clearance from vertical bearing. Tighten set screws* at bottom of transducer assembly.
- f) Place potentiometer adjust thumbwheel on potentiometer shaft and tighten set screw*.
- g) Place potentiometer coupling on potentiometer adjust thumbwheel. Do Not tighten set screw yet.

5. RECONNECT TRANSDUCER WIRES

- a) Using needle-nose pliers or a paper clip bent to form a small hook, gently pull transducer wires through hole in junction box.
- b) Solder wires to circuit board according to wiring diagram. Observe color code.
- c) Secure circuit board in junction box using two screws removed in step 2b. Do not overtighten.

6. REPLACE MAIN HOUSING

- a) Place main housing over vertical shaft bearing rotor. Be careful to align indexing key and channel in these two assemblies.
- b) Place main housing over vertical shaft bearing rotor until potentiometer coupling is near top of main housing.
- c) Turn potentiometer adjust thumbwheel until potentiometer coupling is oriented to engage ridge in top of main housing. Set screw on potentiometer coupling should be facing the front opening.
- d) With potentiometer coupling properly oriented, continue pushing main housing onto vertical shaft bearing rotor until main housing latch locks into position with a "click".

7. ALIGN VANE

- a) Connect excitation voltage and signal conditioning electronics to terminal strip according to wiring diagram.
- b) With mounting post held in position so junction box is facing due south, orient vane to a known angular reference. Details appear in CALIBRATION section.
- c) Reach in through front of main housing and turn potentiometer adjust thumbwheel until signal conditioning system indicates proper value.
- d) Tighten set screw* on potentiometer coupling.

8. REPLACE NOSE CONE

- a) Screw nose cone into main housing until o-ring seal is seated. Be certain threads are properly engaged to avoid cross-threading.

*Max set screw torque 80 oz-in

FLANGE BEARING REPLACEMENT

If anemometer bearings become noisy or wind speed threshold increases above an acceptable level, bearings may need replacement. Check anemometer bearing condition using a Model 18310 Propeller Torque Disc. If necessary, bearings are replaced as follows.

1. REMOVE OLD BEARINGS
 - a) Unscrew nose cone. Set o-ring aside for later use.
 - b) Loosen set screw on magnet shaft collar and remove magnet.
 - c) Slide propeller shaft out of nose cone assembly.
 - d) Remove front bearing cap which covers front bearing.
 - e) Remove both front and rear bearings from nose cone assembly. Insert edge of a pocket knife under bearing flange and lift it out.

2. INSTALL NEW BEARINGS
 - a) Insert new front and rear bearings into nose cone.
 - b) Replace front bearing cap.
 - c) Carefully slide propeller shaft thru bearings.
 - d) Place magnet on propeller shaft allowing 0.5 mm (0.020") clearance from rear bearing.
 - e) Tighten set screw* on magnet shaft collar.
 - f) Screw nose cone into main housing until o-ring seal is seated. Be certain threads are properly engaged to avoid cross-threading.

VERTICAL SHAFT BEARING REPLACEMENT

Vertical shaft bearings are much larger than the anemometer bearings. Ordinarily, these bearings will require replacement less frequently than anemometer bearings. Check bearing condition using a Model 18331 Vane Torque Gauge.

Since this procedure is similar to POTENTIOMETER REPLACEMENT, only the major steps are listed here.

1. REMOVE MAIN HOUSING.
2. UNSOLDER TRANSDUCER WIRES AND REMOVE TRANSDUCER ASSEMBLY. Loosen set screws at base of transducer assembly and remove entire assembly from vertical shaft.
3. REMOVE VERTICAL SHAFT BEARING ROTOR by sliding it upward off vertical shaft.
4. REMOVE OLD VERTICAL BEARINGS AND INSTALL NEW BEARINGS. When inserting new bearings, be careful not to apply pressure to bearing shields.
5. REPLACE VERTICAL SHAFT BEARING ROTOR.
6. REPLACE TRANSDUCER & RECONNECT WIRES.
7. REPLACE MAIN HOUSING.
8. ALIGN VANE.
9. REPLACE NOSE CONE.

WARRANTY

This product is warranted to be free of defects in materials and construction for a period of 12 months from date of initial purchase. Liability is limited to repair or replacement of defective item. A copy of the warranty policy may be obtained from R. M. Young Company.

CE COMPLIANCE

This product has been tested and complies with European CE requirements for the EMC Directive. Please note that shielded cable must be used.

**ENTITY PARAMETERS FOR
YOUNG 05501LM WIND MONITOR IS:**

$V_{max} = 30 \text{ V}$
 $I_{max} = 100 \text{ mA}$
 $C_i = 0.1\mu\text{F}$
 $L_i = 0 \text{ uH}$

USE THE ENTITY PARAMETERS, MINIMUM OPERATING VOLTAGE, INTRINSICALLY SAFE BARRIER SPECIFICATIONS, AND WIRE SPECIFICATIONS TO DETERMINE IF THOSE COMPONENTS WILL FUNCTION WITHIN THE ALLOWABLE SAFETY LIMITS.

THE FOLLOWING RELATIONSHIPS MUST BE MET:

$V_{oc} < V_{max}$
 $I_{sc} < I_{max}$
 $C_a > C_i + C_{cable}$
 $L_a > L_i + L_{cable}$

AT FULL SCALE (20 mA), MINIMUM OPERATING VOLTAGE AT (+) AND (-) TERMINALS MUST BE GREATER THAN 10 VDC

TYPICAL CABLE CAPACITANCE = 60 pF/FT
 TYPICAL CABLE INDUCTANCE = 0.2 uH/FT
 24 AWG WIRE RESISTANCE = 15 OHMS/1000 FT
 (ALWAYS CONFIRM ACTUAL CABLE SPECIFICATIONS.)

EXAMPLE:

MTL 7087+ BARRIER
 300 FT CABLE WITH 24 AWG WIRE
 250 OHM DROPPING RESISTOR

$28 \text{ Voc} < 30 \text{ V}_{max}$
 $93 \text{ mA } I_{sc} < 100 \text{ mA } I_{max}$
 $0.13 \text{ uF } C_a > 0.01 \text{ uF } C_i + 300 \text{ FT} * 60 \text{ pF/FT}$
 $4.2 \text{ mH } L_a > 0.0 \text{ mH } L_i + 300 * 0.2 \text{ uH/FT}$

24.00 V = SAFE SIDE SUPPLY VOLTAGE

6.64 V = VOLTAGE DROP BARRIER PIN 1 TO 4 (20 mA x 332 OHMS)
 1.56 V = VOLTAGE DROP BARRIER PIN 2 TO 5 (20 mA x 33 OHMS + 0.9 V)
 5.00 V = VOLTAGE DROP ACROSS 250 OHM RESISTOR (20 mA x 250 OHMS)
 0.18 V = VOLTAGE DROP IN WIRE (20 mA x 2 WIRES x 300 ft x 15 OHMS/1000 ft)

10.62 V = OPERATING VOLTAGE (24V SUPPLY - SUM OF ALL VOLTAGE DROPS)

ALL VALUES ARE WITHIN ALLOWABLE LIMITS.

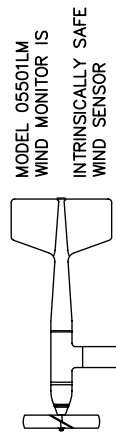

**TYPICAL WIRING INSTALLATION
INTRINSICALLY SAFE BARRIER
MUST BE USED!**

CLASS I
DIVISION 1
GROUPS A, B, C, D

HAZARDOUS (UNSAFE) AREA

NON-HAZARDOUS (SAFE) AREA

BARRIER INTRINSIC SAFETY SPECIFICATIONS
 $V_{oc} = 28 \text{ V}$
 $I_{sc} = 93 \text{ mA}$
 $L_a = 4200 \text{ uH}$
 $C_a = 0.13 \text{ uF}$

MTL 7087+
INTRINSICALLY SAFE BARRIER
332 OHMS FROM PIN 1 TO 4
33 OHMS + 0.9V FROM PIN 5 TO 2

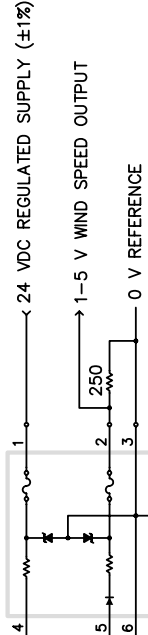

ALL WIRING MUST MEET NEC CODES OR EQUIVALENT. FOR ADDITIONAL GUIDANCE CONSULT ANSI/ISA STANDARD RP 12.6, NEC ARTICLES 500 THROUGH 516, OR CENELEC STANDARD 50.020

BARRIER CIRCUIT SIMPLIFIED FOR VISUALIZATION

MTL 7087+
INTRINSICALLY SAFE BARRIER

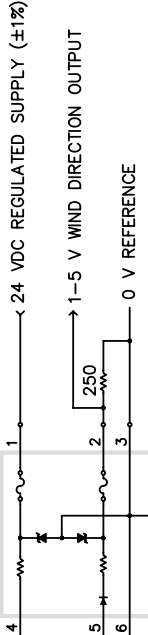

APPROVAL AGENCY MUST BE NOTIFIED OF ALL REVISIONS

WIRING DIAGRAM
 MODEL 05501LM WIND MONITOR IS
 DRAWING NUMBER W05501LM REV B
 FEB 14, 2007
 R. M. YOUNG COMPANY
 TRAVERSE CITY, MI 49696 USA



BEARING REPLACEMENT & POTENTIOMETER ADJUSTMENT

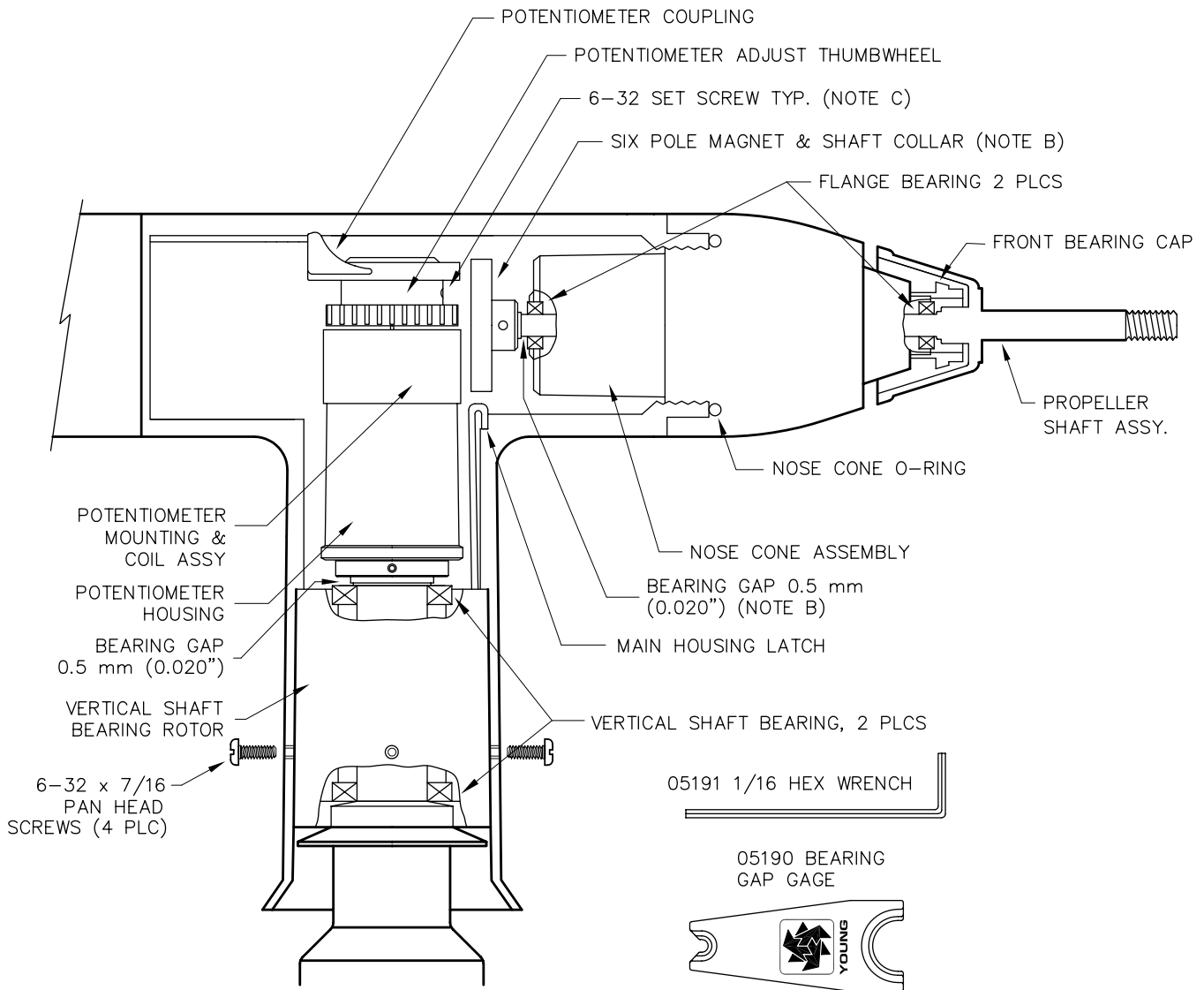

NOTES:

- TO REMOVE HOUSING – UNTHREAD NOSE CONE ASSEMBLY, REMOVE HOUSING SCREWS, PUSH MAIN HOUSING LATCH, LIFT UPWARD.
- TO REPLACE ANEMOMETER FLANGE BEARINGS – UNTHREAD NOSE CONE, REMOVE SIX POLE MAGNET, SLIDE PROPELLER SHAFT AND HUB ASSEMBLY FORWARD, REMOVE FRONT BEARING CAP AND FLANGE BEARINGS. AFTER BEARING REPLACEMENT, SET BEARING GAP TO 0.5mm (0.020")
- TO ADJUST POTENTIOMETER OUTPUT SIGNAL – REMOVE NOSE CONE, LOOSEN SET SCREW IN POTENTIOMETER COUPLING, ADJUST OUTPUT SIGNAL BY MEANS OF POTENTIOMETER ADJUSTMENT THUMBWHEEL, RE-TIGHTEN SET SCREW.



GENERAL ASSEMBLY & REPLACEMENT PARTS

MODEL 05501LM WIND MONITOR

