



# METEOROLOGICAL INSTRUMENTS

## INSTRUCTIONS

### PRECIPITATION GAUGE MODEL 50202 / 50203



## MODEL 50202 PRECIPITATION GAUGE

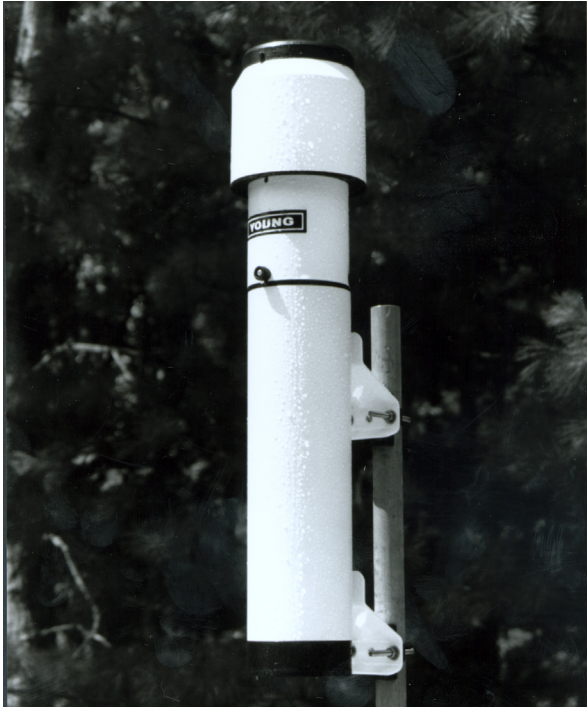

### PRECIPITATION GAUGE SPECIFICATION SUMMARY

<b>Threshold:</b>	<b>1 mm (.04 in)</b>
<b>Accuracy:</b>	<b>± 1 mm (±.04 in)</b>
<b>Signal:</b>	<b>0 to 5.00 VDC = 0 to 50 mm precipitation</b>
<b>Chamber Drain Time:</b>	<b>30 seconds approx.</b>
<b>Power Requirement:</b>	
<b>Measuring Circuit:</b>	<b>8 to 30 VDC unregulated</b>
<b>Heater:</b>	<b>48 Watts @ 28 VAC</b>
<b>Operating Temperature:</b>	<b>-20°C to +50°C (-4°F to 122°F)</b>
<b>Heater Thermostat Set Point:</b>	<b>10°C ± 3°C</b>
<b>Dimensions:</b>	
<b>Height:</b>	<b>65 cm (25.6 in)</b>
<b>Diameter:</b>	<b>14 cm (5.5 in)</b>
<b>Catchment Dia:</b>	<b>133 mm (4.4 in)</b>
<b>Catchment Area:</b>	<b>100 cm<sup>2</sup> (60.8 in<sup>2</sup>)</b>
<b>Mounting:</b>	<b>U-bolts fit vertical pipe 25-50 mm (1-2 in) diameter.</b>
<b>Weight:</b>	<b>2.5 Kg (5.5 lb)</b>
<b>Shipping Weight:</b>	<b>4 Kg (9 lb)</b>

## INTRODUCTION

The Model 50202 Precipitation Gauge accurately measures rain or snow precipitation without moving parts.

Durable thermoplastic construction with no moving parts offers excellent corrosion resistance and long term reliability. Insulated housings and thermostatically controlled heaters permit operation at temperatures below freezing. Unique design with centrally located capacitive sensor is unaffected by unsteady conditions: making the instrument ideal for use on moving platforms such as buoys and ships. For extra security in extreme conditions, Model 50222, Heavy Duty Mounting Bracket is recommended.

Rain or snow collected in the catchment funnel is directed into the measuring chamber; 1mm of precipitation produces a 5mm rise in the chamber. Column level is sensed by a capacitive probe and converted to a linear voltage signal that can be read by external electronics. When the column level reaches a maximum of 250mm (50mm of precipitation), the chamber automatically empties and the process repeats. Total precipitation can be tracked by a datalogger or recorder.

Model 50203 is unheated.

## THEORY OF OPERATION

Model 50202 Precipitation Gauge collects and measures precipitation. Unlike conventional tipping-bucket and weighing gauges the 50202 has no moving parts. Precipitation measurement is made with a capacitive transducer and electronic circuit that produces a calibrated voltage output. Standard output is 0 to 5.00 VDC for 0 to 50mm precipitation with an accuracy of ±1mm. The low power signal conditioning circuit requires 8 to 30 VDC at 3mA. Self contained thermostatically controlled heaters allow operation at temperatures as low as -20°C (-4°F). Collected snow is melted and measured as rainfall equivalent. The heaters operate from 28 volts AC at approximately 48 watts.

Precipitation is collected in a catchment funnel which has a cross sectional area of 100 cm<sup>2</sup>. Captured precipitation drains from this funnel into a measuring tube which has a cross sectional area of 20cm<sup>2</sup>. Since the area of the catchment funnel is 5 times that of the measuring tube, 1mm of captured precipitation produces a 5mm column of water in the measuring tube. A capacitive transducer in the center of the measuring tube senses the water column height. A self contained electronic circuit converts the capacitance value to a calibrated voltage output that is proportional to collected precipitation. Periodic interrogation by a data logging system allows computation of total precipitation and rate.

The full column height of the measuring tube is 250mm representing 50mm of collected precipitation. Additional precipitation starts a self siphon process which empties the measuring tube in approximately 30 seconds. The water column in the tube returns to a level representing 0mm of precipitation and the voltage output goes to 0 VDC. Additional precipitation begins filling the measuring tube again and the cycle is repeated. Evaporation of water remaining in the measuring tube is negligible between siphoning events.

## LOCATION OF RAIN GAUGE

Precipitation measurement is greatly affected by location of the rain gauge. Select a location that is naturally protected from gusts and crosswinds. Avoid a site prone to contamination from debris such as falling leaves, dirt, etc...

## INSTALLATION

The Model 50202 / 50203 is fully calibrated at the factory before shipment, but does require care in the installation and initial priming of the gauge. The following procedure should be followed.

1. The gauge is designed to be installed on a vertical pipe mounting. The mounting U-bolts are intended for use with 3/4 inch to 1 1/2 inch Standard Iron Pipe Size (1.05 in to 1.90 in / 26.7 mm to 48.3 mm)
2. The base of the mounting pipe should be firmly anchored on a level surface so that the sides of the gauge are vertical and the top of the catchment is horizontal.
3. Slide both Mounting Bracket Assemblies (Part No. 50220) over the mounting pipe.
4. Secure the U-bolt of the upper bracket near the top of the mounting pipe. The mounting pipe should not extend above the top of the gauge.
5. Mount the gauge itself on the upper bracket.
6. Slide the lower bracket up so that it engages the lower support of the gauge.
7. Tighten the lower bracket.
8. Tighten the bolts that secure the brackets to the side of the gauge.
9. Verify the top of the catchment is horizontal. If not, loosen the mounting U-bolts and adjust accordingly.
10. Loosen the 3 thumb nuts on the side of the gauge to gain access to the terminal strip for wiring the power, signal, and heater (Model 50202 only) wires.
11. Carefully slide the upper Catchment Assembly (Part No. 50230) up to expose the terminal strip.
12. Connect wires according to enclosed wiring diagram.
13. Before operation the gauge must be primed to provide the necessary reservoir in the bottom of the gauge.
14. Over a 1 minute period slowly pour approximately 500 ml of water into the catchment.
15. When the measuring tube is full, the siphoning action will begin and water will be discharged out the bottom of the gauge. Stop pouring water into the catchment at this time.
16. The gauge is now ready for operation.
17. Connect the power source and signal wires on the other end of the cable to the data logger or display.

## MAINTENANCE

The gauge should be inspected periodically. Accumulated dirt and debris should be cleaned from the catchment area and screen (Part No. 50238). The Measuring Tube Assembly (Part No. 50240) may be removed for cleaning, but this would only be required on a much longer interval.

## WARRANTY

This product is warranted to be free of defects in materials and construction for a period of 12 months from date of initial purchase. Liability is limited to repair or replacement of defective item. A copy of the warranty policy may be obtained from R. M. Young Company.

## CALIBRATION

1. VOLUME CALIBRATION CHECK
  - 1.1 EQUIPMENT NEEDED
    - Water
    - 500 ml graduated cylinder
    - 25 ml syringe
  - 1.2 PROCEDURE
    - 1.2.1 PRIME GAUGE
      - a) Pour water slowly into catchment funnel until unit self siphons.
    - 1.2.2 MEASURE VOLUME
      - a) Pour 490 ml of water into catchment funnel.
      - b) Use syringe to add 5 ml of water very slowly. Measuring tube should be nearly full.
      - c) Use syringe to add more water very slowly. Siphoning should begin before 10 ml is added: tolerance is 495 - 505 ml, ( $\pm 1\%$ ). Catchment funnel is 100 cm<sup>2</sup> and measuring tube is 20 cm<sup>2</sup> (5:1 ratio). 1 mm of collected precipitation equals 5 mm of measuring tube depth.
2. ELECTRONIC CALIBRATION
  - 2.1 EQUIPMENT NEEDED
    - Water
    - 500 ml graduated cylinder
    - Fixed DC power source (12 to 24 VDC)
    - Voltmeter
    - 25ml syringe
  - 2.2 PROCEDURE
    - 2.2.1 MAKE ELECTRICAL CONNECTIONS
      - a) Refer to wiring diagram for proper connections.
      - b) Connect 12 to 24 VDC to power input.
      - c) Connect a voltmeter to circuit output.
    - 2.2.2 PRIME GAUGE
      - a) Pour water slowly into the catchment funnel until the unit self siphons.
    - 2.2.3 CALIBRATE VOLTAGE OUTPUT FOR ZERO
      - a) Turn ZERO trimpot (R4) on circuit board until a positive change is observed in the voltage output.
      - b) Then turn trimpot until voltage output just reaches 00.0 volts. Do not turn it any further.
    - 2.2.4 CALIBRATE VOLTAGE OUTPUT FOR FULL SCALE
      - a) Pour 450 ml into catchment funnel.
      - b) Adjust GAIN trimpot (R13) for 4.50 VDC on the output. Output voltage is now scaled for 20 mV per millimeter of water depth in the measuring tube which equals 100 mV per millimeter of precipitation.
    - 2.2.5 CHECK OUTPUT LINEARITY
      - a) Pour water slowly into catchment funnel until unit self siphons.
      - b) Add 50 ml of water and observe output voltage.
      - c) The output voltage is calculated using the ratio of 500 mV per 50 ml. Gauge accuracy is specified as  $\pm 1$  mm of collected precipitation. Measured output voltage should be within  $\pm 100$  mV of the calculated value.
      - d) Continue adding water in 50 ml increments and observing voltage output until measuring tube is full at 500 ml total volume. Measured output voltage should be within  $\pm 100$  mV of the calculated value at each 50 ml increment.



MODEL 50202  
PRECIPITATION GAUGE

CAPACITIVE MEASUREMENT  
NO MOVING PARTS  
AUTOMATIC SELF SIPHONING  
LOW POWER MEASURING CIRCUIT

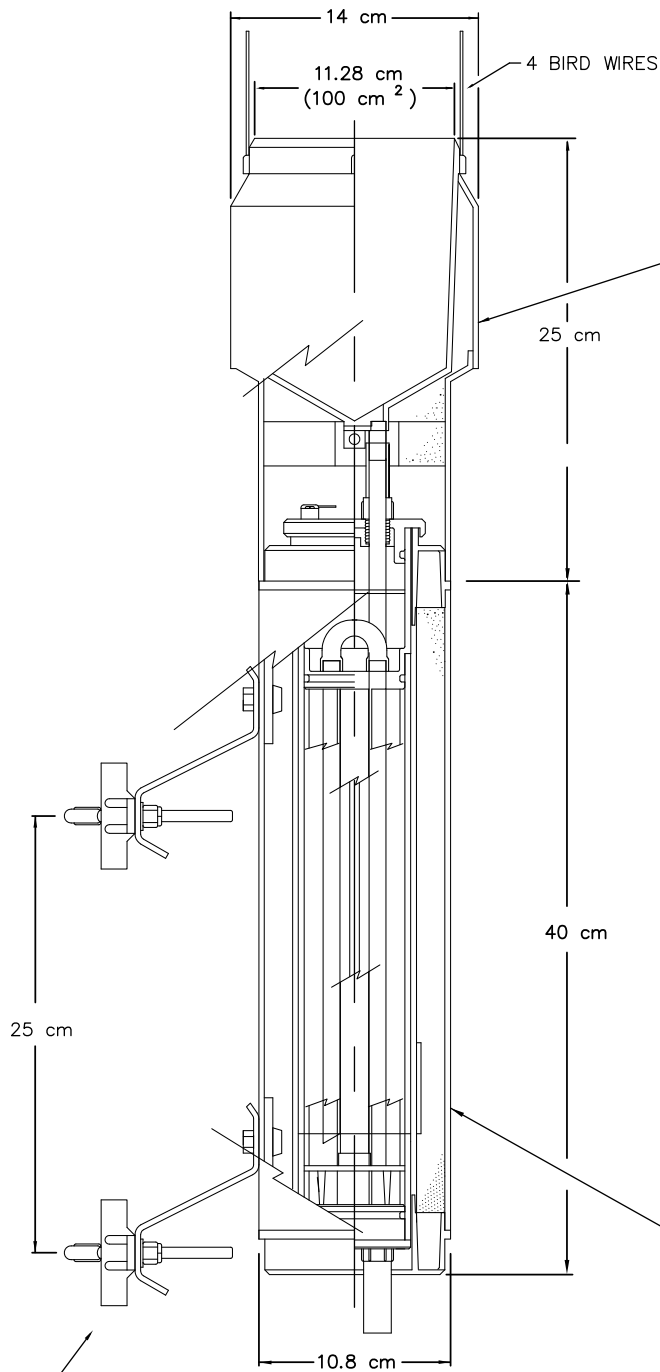

INSULATION JACKET WITH OPTIONAL  
20W/24VAC HEATER & THERMOSTAT

SPECIFICATIONS
MEASURING RANGE: 0 TO 50 mm STANDARD (50202) (AUTOMATICALLY EMPTIES AND REPEATS MEASUREMENT)
THRESHOLD: 1mm (0.05")
ACCURACY: ± 1mm (± 0.1")
OUTPUT SIGNAL: 0 - 5 VDC (ADJUSTABLE - OTHER OUTPUT LEVELS CAN BE PROVIDED.)
CIRCUIT POWER: 8 - 30 VDC (< 3mA) UNREGULATED
OPERATING TEMPERATURE: >0° C TO 50° C -20° C TO + 50° C WITH 24 VAC HEATERS
THERMOSTAT SET POINT: 10°C ± 3°C
WEIGHT: 2.5 KG (5.6 LBS)
SHIPPING WT: 4 KG (9 LBS) APPROX.

INSULATION JACKET WITH OPTIONAL  
26W/24VAC HEATER & THERMOSTAT

UNIVERSAL TYPE MOUNTING BRACKETS  
(U-BOLT FITS 25-50mm [1-2 INCH]  
DIAMETER MOUNTING PIPE)

MODEL 50202 PRECIPITATION GAUGE	DWG D	PRD 08/88
SPECIFICATION & OUTLINE DRAWING	DWN JMT	DWN 01/15
	CHK <i>[Signature]</i>	S50202(pg4)(D)
R.M. YOUNG CO. TRAVERSE CITY, MI 49686 U.S.A. 231-946-3980		

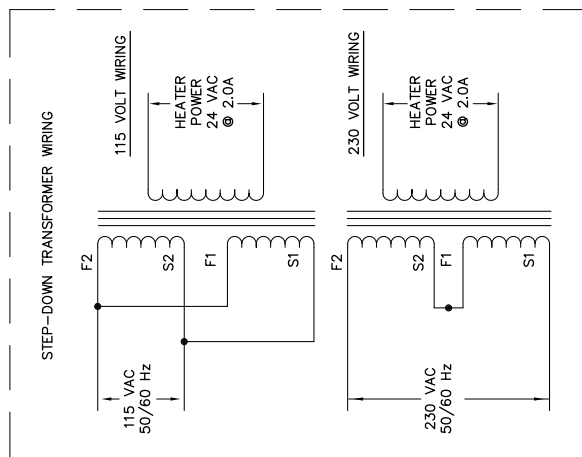

MODEL 27060  
24V TRANSFORMER ASSY

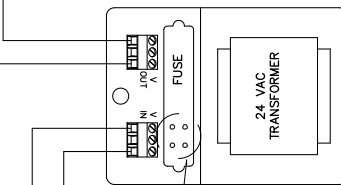

VOLTAGE SELECTED BY JUMPER CONFIGURATION UNDER FUSE COVER

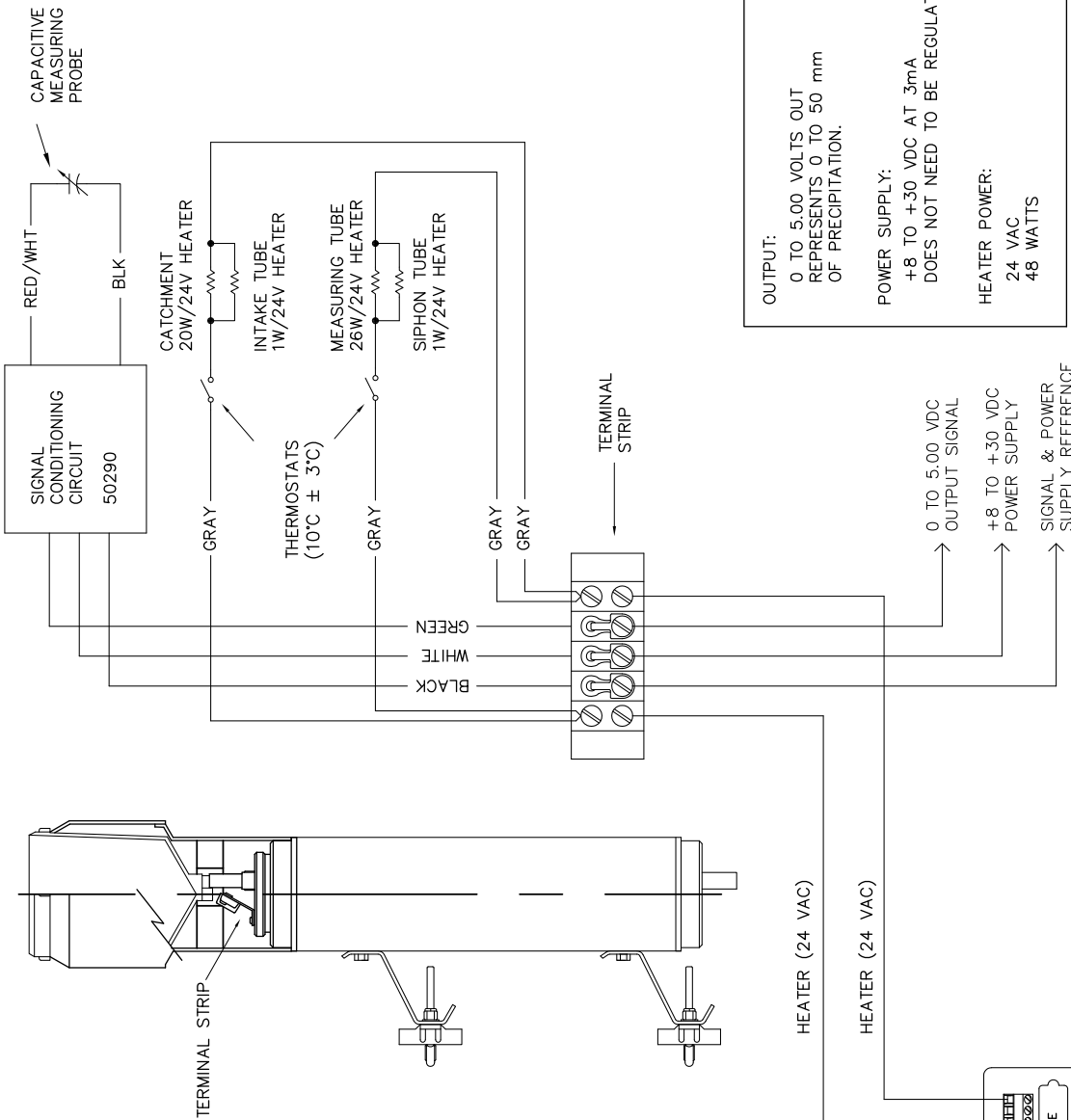

OUTPUT:  
 0 TO 5.00 VOLTS OUT REPRESENTS 0 TO 50 mm OF PRECIPITATION.

POWER SUPPLY:  
 +8 TO +30 VDC AT 3mA DOES NOT NEED TO BE REGULATED.

HEATER POWER:  
 24 VAC  
 48 WATTS

0 TO 5.00 VDC OUTPUT SIGNAL

+8 TO +30 VDC POWER SUPPLY

SIGNAL & POWER SUPPLY REFERENCE

MODEL 50202 PRECIPITATION GAUGE	DWG C	PRD 08/88
WIRING DIAGRAM	DWN JMT	DWN 01/15
	CHK <i>[Signature]</i>	W50202(pgs)(c)
R.M. YOUNG CO. TRAVERSE CITY, MI 49686 U.S.A. 231-946-3980		





MODEL 50202  
PRECIPITATION SENSOR 0 - 50 MM

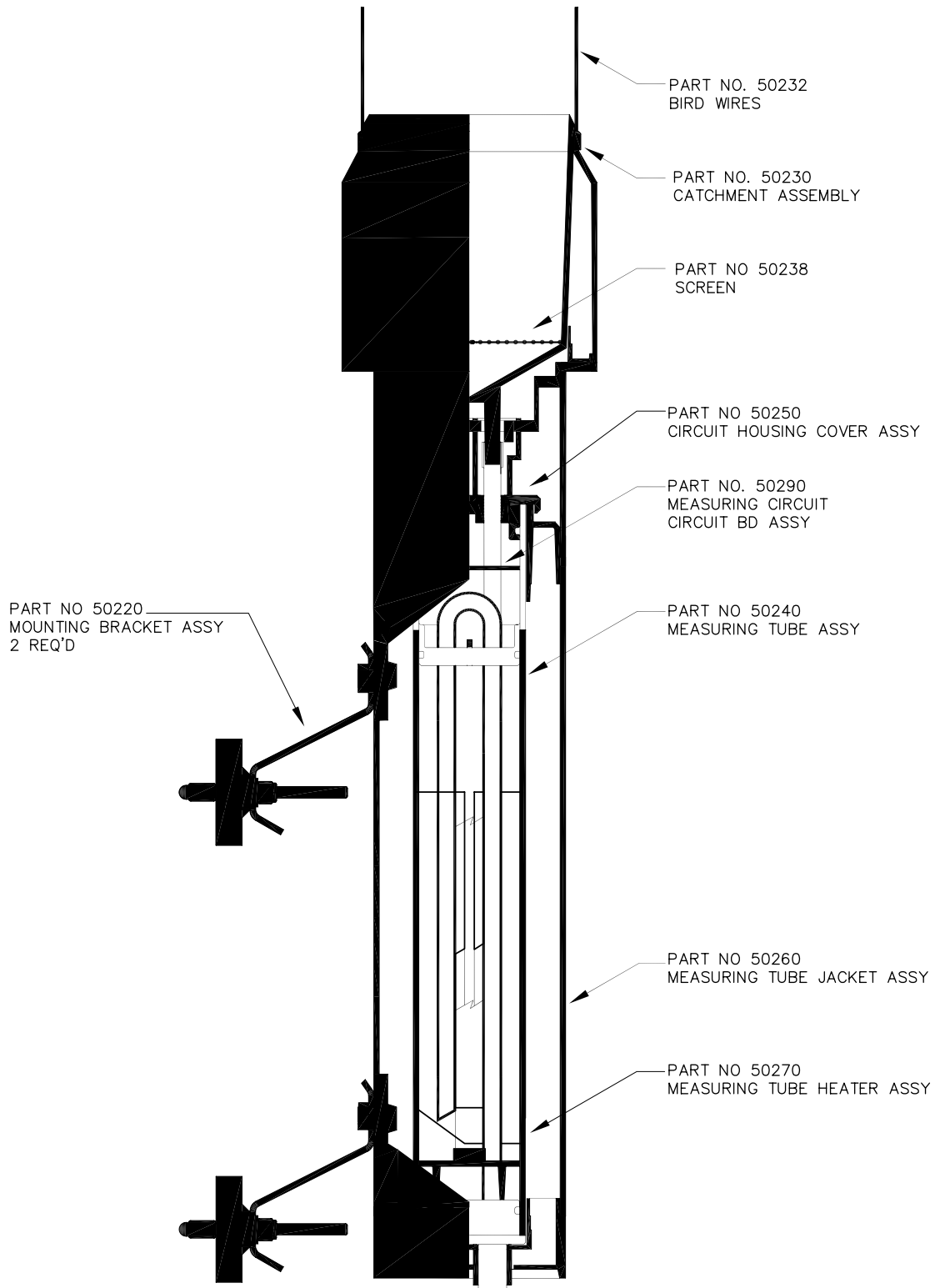

MODEL 50202 PRECIPITATION GAUGE	DWG B	PRD 08/88
REPLACEMENT PARTS	DWN KL	DWN 11/99
	CHK	S50202(pg7)(B)
R.M. YOUNG CO. TRAVERSE CITY, MI 49686 U.S.A. 231-946-3980		