



INTRODUCTION

The Model 61002 Gill Pressure Port provides an effective static pressure inlet for a barometric pressure sensor.

Measurement performance of remote barometers can be seriously impaired by the effects of wind at the barometer inlet. Ambient wind of 20 meters/second blowing over a typical barometer inlet tube can cause dynamic pressure errors as high as 3 millibars.¹ These errors can make atmospheric pressure data useless for research and forecast purposes. The Gill Pressure Port reduces dynamic pressure errors to a minimum level.

The unique parallel plate design of the Pressure Port effectively slows air velocity at the pressure inlet. A simple internal baffle system creates a barrier to water and snow intrusion into the barometer.

The Gill Pressure Port features durable, corrosion resistant plastic construction for long service and minimum cost.

INSTALLATION

The Gill Pressure Port is designed for use with YOUNG Model 61201 Barometric Pressure Sensor. Barbed fittings are supplied with both devices for easy interconnection using 3/16 inch ID flexible tubing. The Pressure Port works well with other barometers, however, barbed fittings may be sized differently. The installation procedure is as follows:

1. Select a location that is away from sources of contamination. For marine use, the pressure port should be located as high above the water as practical. For land installations, dirty and dusty locations should be avoided.
2. Securely attach pressure port to vertical pipe using U-bolt mounting. Connect 3/16 ID inch flexible tubing to barbed fitting.
3. Route flexible tubing to barometric pressure sensor location. Connect to barbed fitting on pressure sensor.

The pressure port is designed to exclude moisture. In use, however, condensation in the flexible tubing may cause water to collect. If this occurs, the tubing should be drained to prevent blockage. A T-fitting and sump may be installed. If allowed to accumulate, water blockage in the tubing will cause incorrect pressure readings.

1. Development and Testing of a No-Moving-Parts Static Pressure Inlet for Use on Buoys- Gerald C. Gill

SPECIFICATIONS

Dynamic Pressure Error:	0.5 mb max. @ 20m/s
Dimensions:	
Height:	16.2 cm (6.4 in)
Diameter:	13.0 cm (5.1 in)
Mounting:	Offset bracket w/U-bolt for 25 to 50 mm (1 - 2 in) diameter pipe
Weight:	0.5 lb (0.2 Kg)

PRESSURE PORT ASSEMBLY

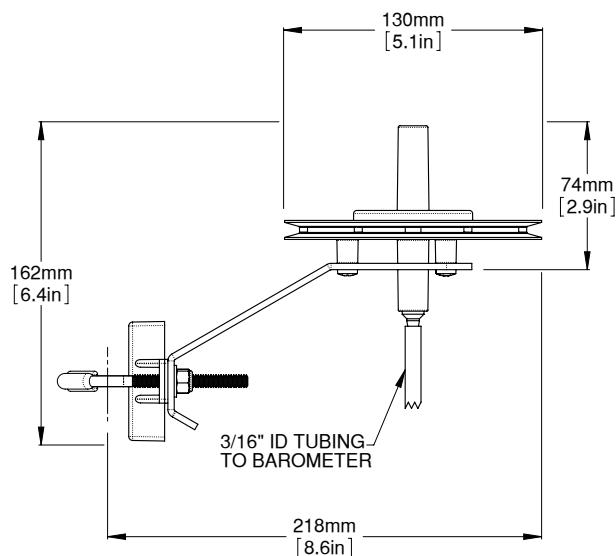

MOUNTING CLAMP:
Ø 25.0 - Ø 50.0 mm (1.00 - 2.00 in)
(STANDARD 3/4" TO 1-1/2" IRON PIPE)